

## Schottky Barrier Diode

### FEATURES

- Low current rectification
- Low forward voltage
- SOD523 Micro SMD package
- RoHS compliant
- Cathode Band / Device marking
- Marking:C

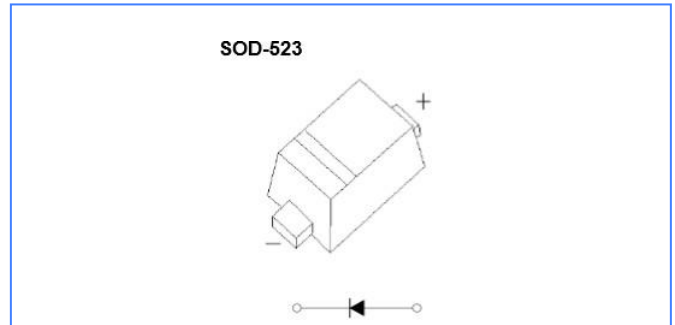

### Maximum Ratings (Ta = 25 °C)

Symbol	Parameter	Value	Units
V <sub>RRM</sub>	Repetitive Peak Reverse Voltage	30	V
V <sub>RWM</sub>	Working Peak Reverse Voltage	30	V
I <sub>O</sub>	Continuous Forward Current	200	mA
I <sub>FSM</sub>	Non-Repetitive Peak Forward Surge Current *1	1.0	A
P <sub>D</sub>	Power Dissipation	150	mW
R <sub>θJA</sub>	Thermal Resistance Junction to Ambient	667	°C/W
T <sub>J</sub>	Junction Temperature	125	°C
T <sub>STG</sub>	Storage Temperature	-55 to +125	°C

### Electrical Characteristics Ratings at 25°C ambient temperature unless otherwise specified

Symbol	Parameter	Conditions	Min	Max	Units
V <sub>F</sub>	Forward Voltage	I <sub>F</sub> = 10mA		0.35	V
		I <sub>F</sub> = 200mA		0.50	V
I <sub>R</sub>	Reverse current	V <sub>R</sub> = 10V		30	μA

### Typical Characteristics

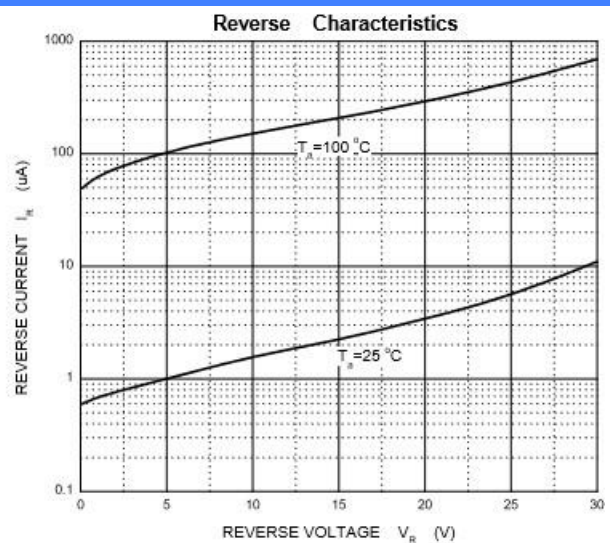
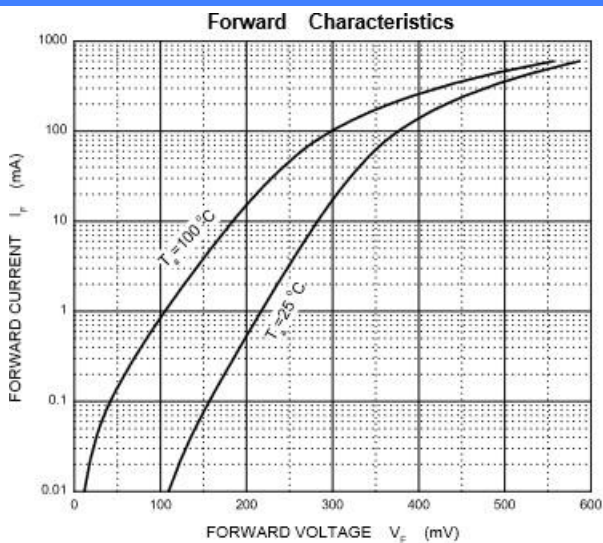

Capacitance Characteristics

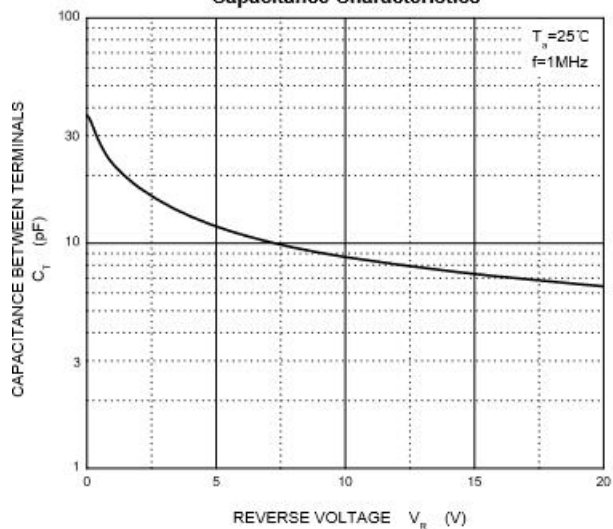

Power Derating Curve

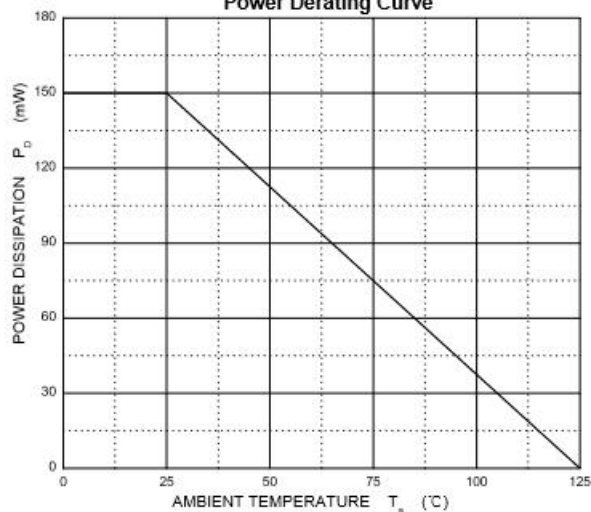

Package Dimensions

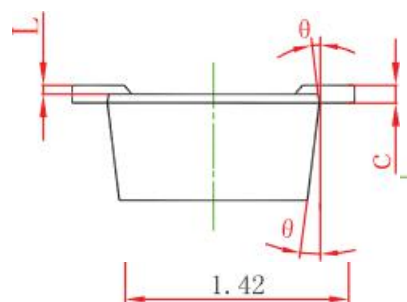
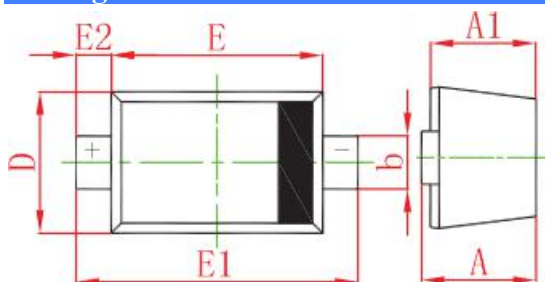

Symbol	Dimensions in mm		Dimensions in inches	
	min	max	min	max
A	0.510	0.770	0.020	0.031
A1	0.500	0.700	0.020	0.028
b	0.250	0.350	0.010	0.014
c	0.080	0.150	0.003	0.006
D	0.750	0.850	0.030	0.033
E	1.100	1.300	0.043	0.051
E1	1.500	1.700	0.059	0.067
E2	0.200REF		0.008	
L	0.010	0.070	0.001	0.003
θ	7° REF		7°REF	

Disclaimer

Specifications are subject to change without notice.

The device characteristics and parameters in this data sheet can and do vary in different applications and actual device performance may vary over time.

Users should verify actual device performance in their specific applications.